

# KOBELCO

SK45SRX-7/SK55SRX-7

Performance  Design

## SK45SRX SK55SRX

■ **Bucket capacity:**

SK45SRX 0.14 m<sup>3</sup>

SK55SRX 0.16 m<sup>3</sup>

■ **Engine power:**

29.1 kW / 2,400 min<sup>-1</sup> (ISO 14396)

■ **Operating weight:**

(The following figures are only available when the counterweight is standard.)

SK45SRX 4,660–4,980 kg

SK55SRX 5,090–5,450 kg



**We Save You Fuel**  
Achieving a Low-Carbon Society

# Performance Design

With the release of the SK45SRX-7 and SK55SRX-7, KOBELCO has completely harmonised the values of PERFORMANCE and DESIGN. These mini excavators deliver greater efficiency and productivity with increased power and speed, along with uncompromising operator comfort and machine operability.

In the pursuit of producing unique and unbeatable machines that provide comfort and productivity without equal, KOBELCO continues to rise to the challenge.





# UNFORGETTABLE COMFORT

True ergonomic functionality combined with modern design has resulted in a cabin interior that is sleek and comfortable.





### Suspension seat

A proven Grammer suspension seat is fitted as standard, offering a reclining mechanism, shock absorber, and excellent seating comfort.

### Wrist rest

The enlarged wrist rests keep the operator's forearms in a stable position, reducing fatigue and allowing for stable operation.



### Air conditioner

Additional air vents provide a uniform air flow in front of and behind the operator and direct the air flow onto the window, improving the defroster's dehumidification function.



### Switches with LED backlights

LED backlighting on switches and dials provides a bright, clear view of controls, even in the dark, while delivering a premium look and feel.



### Smartphone holder/ USB/AUX port

# FUNCTIONAL WORK ENVIRONMENT

Built for simplicity and operator comfort.



## Colour monitor

The bright colour display is easy to read and shows important information such as operating history, maintenance requirements, and fuel and coolant temperature gauges. It can also be used to adjust the hydraulic oil flow to the attachments.



## Hydraulic flow adjustment (Option)

Rotation or N&B piping flow can be selected from six preset types, or adjusted arbitrarily.



## Maintenance information



## Energy Conservation Mode

The SK45SRX/SK55SRX adapts S-mode which enables 26% (SK55SRX only) less fuel consumption compared to H-mode.



## Auto deceleration switch

Auto deceleration switch installed as standard. Easy-to-use switch control.



## Operation history

### Easy access

The wide opening door, along with a redesigned safety lockout lever shape, provides excellent cabin access.

### Slide-open window

The window on the right side of the cab can be opened and closed both forwards and backwards to facilitate ventilation and to ease communication on worksites.



### Lever angles allow for comfortable operations

The operator can move the levers horizontally without twisting their wrist, reducing operator fatigue.

### Proportional hand control lever for rotation & N&B piping

Precise proportional controls are integrated into the joystick for ease of operation.



**FM/AM radio & AUX & Bluetooth® & hands-free telephone**



**Speaker**



**12V power outlet**



**Coat hook**



**Cup holder**



**LED door light**



# THE NEXT LEVEL OF PERFORMANCE

## A new hydraulic system

The new hydraulic system is significantly improved compared to previous models, with substantially faster digging cycle times. It delivers high performance without a reduction in speed, even when a heavy load is applied or when travelling on a slope.

By replacing the travel motor and swivel joint, the travel speed is increased.

### >>> Travel speed

Faster by **12%** (SK55SRX)

Faster by **5%** (SK45SRX)

(Compared to previous models with two speeds)

### >>> Hill-climbing speed

Faster by **10%** (SK55SRX)

(Compared to previous models)

By replacing the spool, the power loss is reduced, resulting in higher digging and swing speeds.

### >>> Digging cycle time

Shortened by **11%** (SK55SRX)

Shortened by **4%** (SK45SRX)

(Compared to previous models)



## Smoother operation

The new hydraulic system improves levelling performance and makes dozer work easier, even with heavier attachments installed.

## Integrated Flow Pump System

The instant the machine begins to dig, extra output from the third pump (which otherwise powers the swing and dozer circuit) is directed to the arm circuit and boom circuit (raise) for added power. This ensures fast and smooth arm and boom raising operation even under heavy loads.

Only SK55SRX.  
SK45SRX does not direct output from No.3 pump to the bucket.

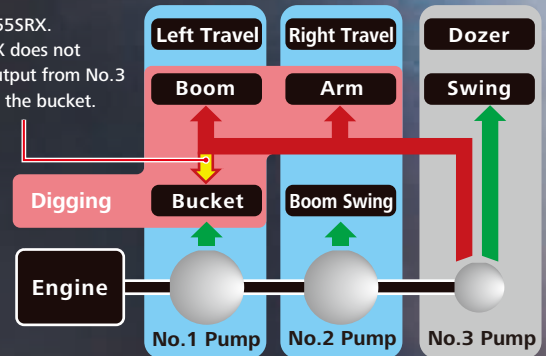

# COMPACT SIZE, BIG PERFORMANCE

Min. swing radius at boom swing  
(SK55SRX with standard arm)



\*SK45SRX: 1,990 mm (Cab)  
1,940 mm (Canopy)



## Short tail swing

The compact tail swing improves operating efficiency in limited space.

## Tail overhang:

**190 mm (290 mm)**

Figure in ( ) shows the value of with additional counterweight.



5,900 mm (SK45SRX)  
6,270 mm (SK55SRX)

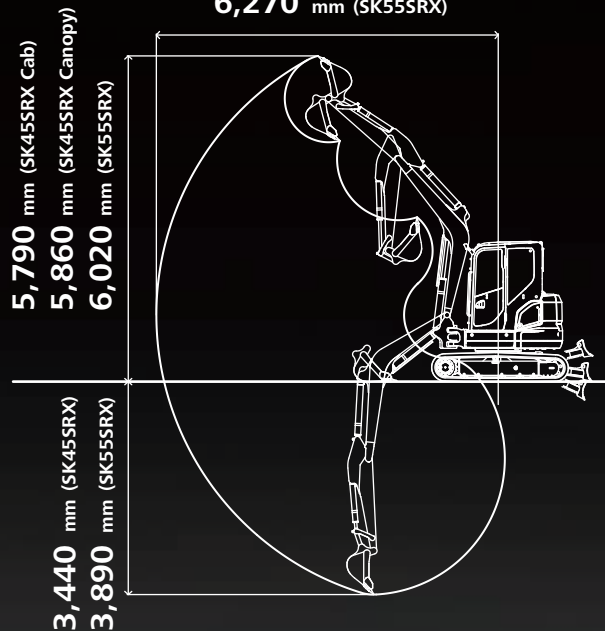

## Wide working range

A larger boom and arm are provided as standard equipment to ensure a wide working range.

# VERSATILITY



## Easy hydraulic piping for quick hitch

Various attachments, such as the bucket, can be easily mounted and dismantled without leaving the cab, increasing working speed.



## Dozer lever

The shape and angle of the dozer lever have been improved to make it easier to grip, and the first and second speed switches have been moved to the dozer lever to improve manoeuvrability when dozing. With the front dozer specification, functions can be switched on and off conveniently.



## Dozer-blade shape

KOBELCO's unique blade design pushes the earth into an arc that always falls forward. Because this prevents material from falling behind the blade, only one pass is needed.



## Angle dozer (Option)



## Floating dozer (Option)

A floating dozer is fitted as optional equipment, contributing to easy levelling work.

# LEGENDARY RELIABILITY

The boom, arm and swing bracket all have large cross-section segments for added attachment strength.

## Forged boom top

## Boom cylinder guard

## Plate type pin

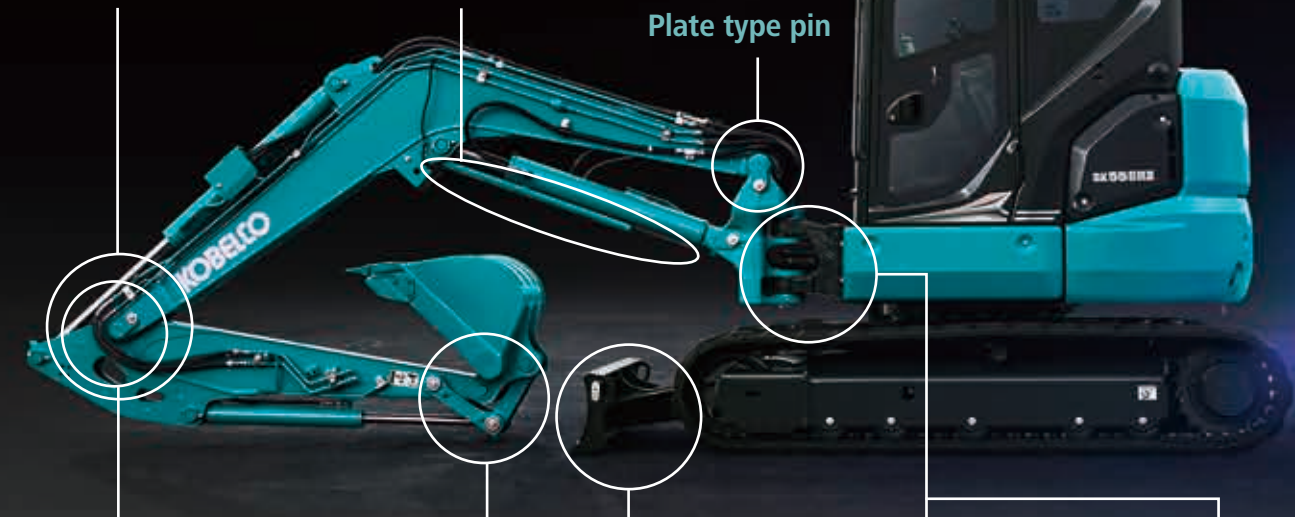

## Bucket

Cast-iron idler link provides greater strength.



## Dozer

Box construction dozer supports provide greater strength.



## Swing bracket

Large, thick cast-iron swing bracket/front bracket.



## Hydraulic hosing

The hydraulic hosing is housed inside the swing bracket.

## Bolt-tightened pins

Bolt-tightened pins firmly lock the boom to prevent the boom top from opening laterally.

# NON-STOP OPERATION BY iNDr

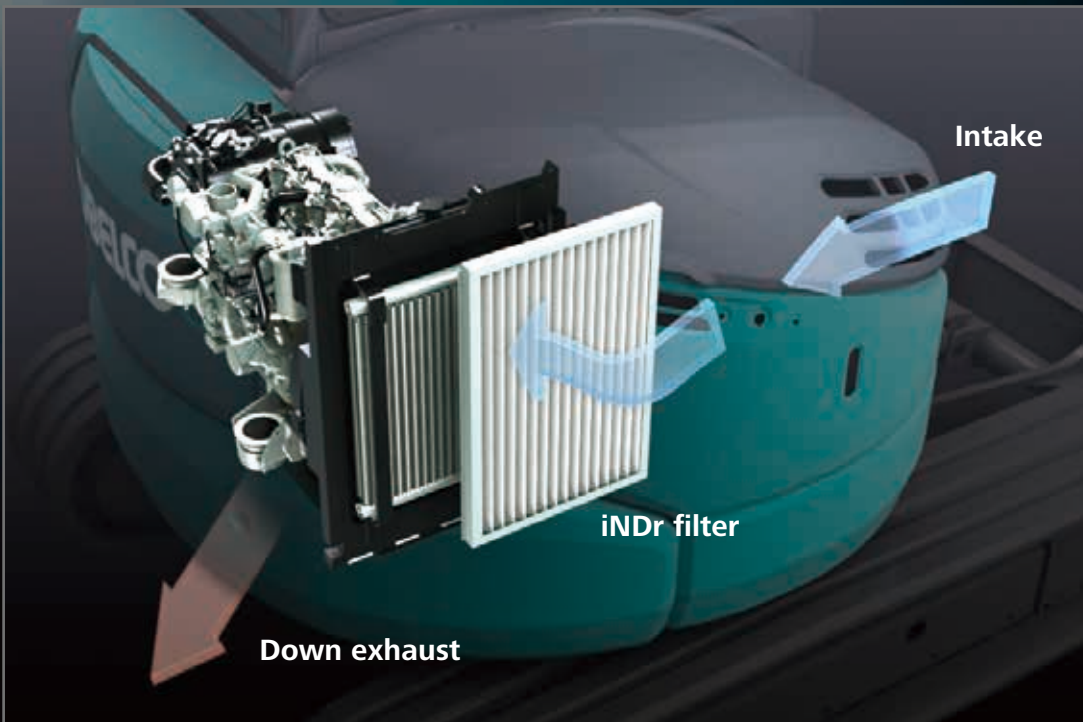

## iNDr filter

A high-density mesh filter blocks dust intruding during air intake. This prevents the cooling device and the air cleaner from clogging with dust and maintains their performances. The ridges of the corrugated filter allow the air to pass through, and the grooves collect the dust, which prevents the filter from clogging.

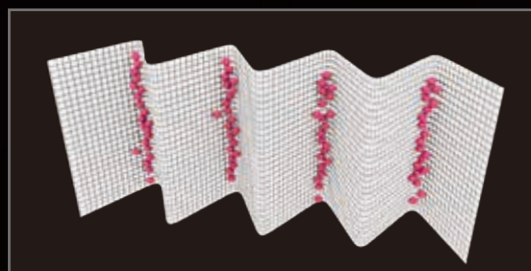

The iNDr filter has a high-density mesh of 30 lines per inch to collect dust.

# EASY MAINTENANCE

Easy daily maintenance to reduce machine downtime.



## Easy Access to Component Inside the Cab



Hour meter



Air conditioner filter for outer air intake



Air conditioner filter for internal air circulation



Instruction manual storage box

## Easy Access to Cooling Unit



### iNDR filter

Laid out for easy access to radiator and cooling system.

## Easy Access to Engine Compartment



### ① Pre fuel filter with built-in water separator

The position of the pre fuel filter has been changed to make it more accessible.

### ② Air cleaner

### ③ High-grade fuel filter

# OPERATOR SAFETY



## Reliable cab/canopy structure

The high-strength cab/canopy meets ROPS, TOPS and OPG Level 1 (Top guard) standards for greater operator safety.



## Good visibility

The wiper mount has been moved to the upper right of the cab support and the skylight opening has been enlarged, improving visibility to the front and above.



Rear view mirror



Rear lower mirror



Hammer for emergency exit

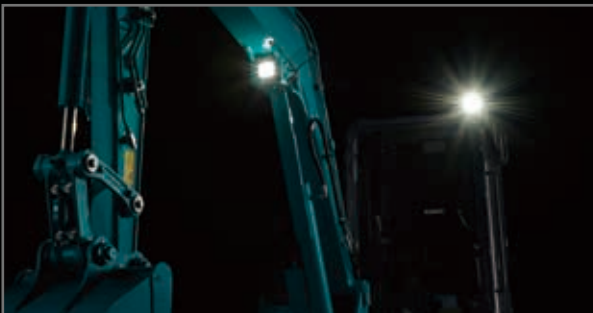

## LED work light

Work light is mounted under the boom to protect it from damage.



## Accumulator for emergency attachment lowering

An installed accumulator allows the attachment to be safely lowered to the ground using in-cab controls in the event of an unexpected engine shutdown and provides class-leading smooth operation.

## STANDARD EQUIPMENT

- ENGINE**
- Engine, YANMAR 4TNV88C-PYBD, diesel engine, Tier 4 Final
  - Battery (1 × 12 V - 74 Ah)
  - Starting motor (12 V - 2.3 kW), 55 amp alternator
  - Double element air cleaner
- CONTROL**
- N&B piping with stop valve
  - Foot control for N&B piping
  - Dozer lever
  - Dozer blade
  - Auto deceleration
  - Accelerator dial
  - Energy Conservation Mode
  - BHL lever
  - Quick hitch piping
- SWING SYSTEM & TRAVEL SYSTEM**
- Foot control for travelling
  - Two-speed travel with automatic shift down
  - 400 mm rubber shoe
  - Grease-type track adjusters
  - Automatic swing brake
  - Travel alarm
- MIRRORS & LIGHTS**
- Rear view mirror
  - Rear lower mirror
  - Cab LED working light\*
  - LED working light on boom
- CABIN**
- Suspension seat (Cab: fabric / Canopy: PVC)
  - Retractable seatbelt
  - Air conditioner\*
  - FM/AM radio (AUX & Bluetooth®)\*
  - Hands-free telephone\*
  - Multi-function colour monitor
  - Cup holder
  - Smartphone holder\*
  - LED door light\*
  - 12 V power outlet
  - Coat hook\*
  - Emergency exit hammer\*
  - Detachable two-piece floor mat
  - Skylight\*
  - Tinted safety glass\*
  - Pull-type front window and removable lower front window\*
  - Wrist rest
  - USB port\*
  - Speaker\*
  - Grease gun

## OPTIONAL EQUIPMENT

- Canopy LED working light
- 400 mm steel shoe
- Floating dozer
- Angle dozer
- Additional counterweight (+ 250 kg)
- Arm & bucket cylinder rod guard
- Boom & arm safety valve
- N&B (HCP) piping with stop valve
- N&B (HCP) piping + Rotating N&B (HCP) piping with stop valve
- Front guard
- Top guard\*
- Multi-control valve
- 0.086 m<sup>3</sup> (450 mm) bucket
- 0.14 m<sup>3</sup> (600 mm) bucket (only for SK45SRX)
- 0.16 m<sup>3</sup> (650 mm) bucket
- 0.18 m<sup>3</sup> (750 mm) bucket

\*Only for Cab

Note: Figures in the above table show the value with standard arm (SK45SRX: 1.55 m, SK55SRX: 1.69 m) specs.

Regarding bucket capacity, 0.14 m<sup>3</sup> in this catalogue is equivalent to 0.12 m<sup>3</sup> in ISO 07451 and 0.16 m<sup>3</sup> in this catalogue is equivalent to 0.13 m<sup>3</sup> ISO 07451.

Bluetooth® is a registered trademark of the Bluetooth SIG Inc.

Standard and optional equipment may vary. Consult your KOBELCO dealer for specifics.

# Specifications

## Engine

Model	YANMAR 4TNV88C-PYBD
Type	Four-stroke, liquid-cooled, direct injection diesel, complies with Tier 4 Final exhaust emission regulation
No. of cylinders	4
Bore and stroke	88 mm x 90 mm
Displacement	2.189 L
Rated power output	27.7 kW/2,400 min <sup>-1</sup> (ISO 9249: with fan)
	29.1 kW/2,400 min <sup>-1</sup> (ISO 14396: without fan)
Max. torque	136.8 N·m/1,560 min <sup>-1</sup> (ISO 9249: with fan)
	139.1 N·m/1,560 min <sup>-1</sup> (ISO 14396: without fan)

## Hydraulic system

Pump	
Type	Two variable displacement axial piston pumps + one gear pump + pilot pump
Max. discharge flow	SK45SRX 2 x 49.9 L/min 1 x 33.8 L/min 1 x 10.8 L/min
	SK55SRX 2 x 53 L/min 1 x 33.8 L/min 1 x 10.8 L/min
Relief valve setting	
Boom, arm and bucket	23.0 MPa
Travel circuit	23.0 MPa
Swing circuit	20.1 MPa
Blade circuit	22.0 MPa
Control circuit	3.5 MPa
Pilot control circuit	Gear type
Main control valves	11-spool
Oil cooler	Air cooled type

## Swing system

Swing motor	One fixed displacement piston motor
Brake	Hydraulic; locking automatically when the swing control lever is in the neutral position
Parking brake	Wet multiple plate
Swing speed	8.5 min <sup>-1</sup>
Tail swing radius	1,170 mm
Swing torque	12.4 kN·m

## Travel system

Travel motors	Two variable displacement piston motors	
Travel brakes	Hydraulic brake	
Parking brakes	Wet multiple plate	
Travel shoes	38 each side (steel shoe)	
Travel speed	SK45SRX	4.2/2.2 km/h (rubber shoe) 3.9/2.1 km/h (steel shoe)
	SK55SRX	4.5/2.4 km/h (rubber shoe) 4.2/2.2 km/h (steel shoe)
Drawbar pulling force	SK45SRX	54.7 kN (Cab) 54.8 kN (Canopy)
	SK55SRX	54.4 kN (Cab) 54.5 kN (Canopy)
Gradeability	58% {30°}	

## Cabin & control

Cabin
Cab: Fully enclosed steel structure
Canopy: Four posts canopy
Control
Two hand levers and two foot pedals for travel
Two hand levers for excavating and swing
Electric rotary-type engine throttle
Foot control (for boom swing)
Foot control (for N&B piping)
Dozer lever

## Boom, arm & bucket

Model	SK45SRX		SK55SRX	
	Cab	Canopy	Cab	Canopy
Boom cylinder	100 mm x 695 mm	100 mm x 702 mm	100 mm x 699 mm	
Arm cylinder	80 mm x 702 mm		90 mm x 716 mm	
Bucket cylinder	75 mm x 546 mm			
Swing cylinder	90 mm x 574 mm			

bore x stroke

## Dozer blade

Dozer cylinder	90 mm x 200 mm
Dimension	1,960 mm (width) x 345 mm (height)
Working range	465 mm (up) x 335 mm (down)

## Refilling capacities & lubrications

Fuel tank	75 L
Cooling system	8.5 L
Engine oil	7.5 L
Travel reduction gear	2 x 0.8 L
Hydraulic oil tank	SK45SRX 27.9 L tank oil level 58 L hydraulic system
	SK55SRX 27.9 L tank oil level 59 L hydraulic system



# SK45SRX SK55SRX

## Working ranges

Unit: m

Model	SK45SRX		SK55SRX	
	Cab	Canopy	Cab	Canopy
Arm length	1.55 m		1.69 m	
a- Max. digging reach	5.90		6.27	
b- Max. digging reach at ground level	5.75		6.13	
c- Max. digging depth	3.44		3.89	
d- Max. digging height	5.79	5.86	6.02	
e- Max. dumping clearance	4.19	4.26	4.44	
f- Min. dumping clearance	1.55	1.61	1.60	
g- Max. vertical wall digging depth	3.00		3.23	
h- Min. swing radius at boom straight	2.41	2.36	2.31	
h'- Min. swing radius at boom swing	1.99	1.94	1.90	
i- Horizontal digging stroke at ground level	2.55		2.96	
j- Digging depth for 2.4 m (8') flat bottom	3.05		3.49	
k- Dozer blade (height/depth) (mm)	465/335			

\*Figures in the above table show the value with 0.14–0.16 m<sup>3</sup> ISO heaped bucket. Regarding bucket capacity, 0.14 m<sup>3</sup> in this catalogue is equivalent to 0.12 m<sup>3</sup> in ISO 07451 and 0.16 m<sup>3</sup> in this catalogue is equivalent to 0.13 m<sup>3</sup> ISO 07451.

## Digging force (ISO 6015)

Unit: kN

Model	SK45SRX		SK55SRX	
	Cab	Canopy	Cab	Canopy
Arm length	1.55 m		1.69 m	
Bucket digging force	35.6			
Arm crowding force	20.9		24.8	

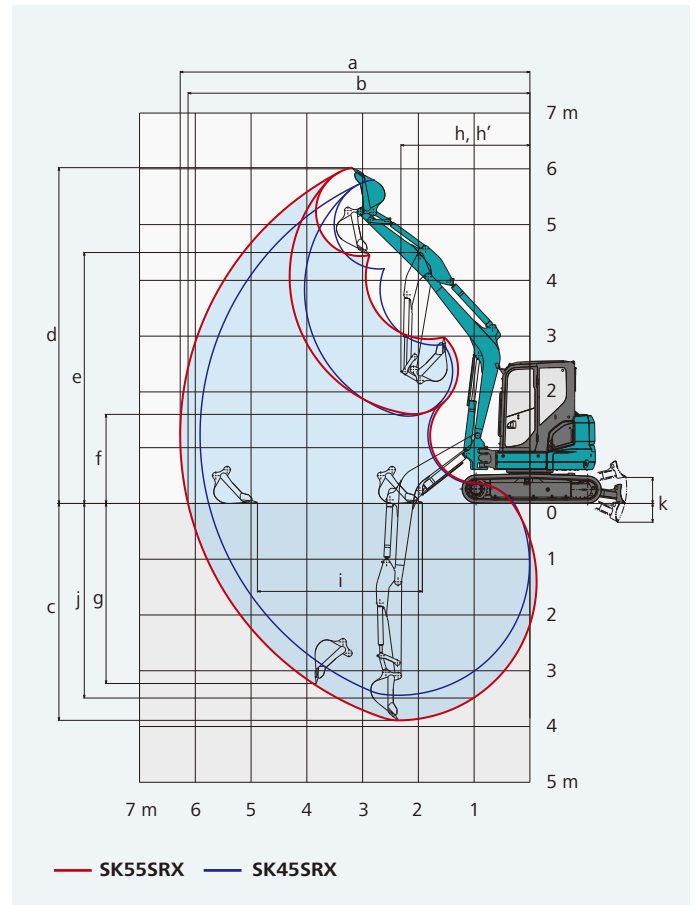

## Dimensions

Unit: mm

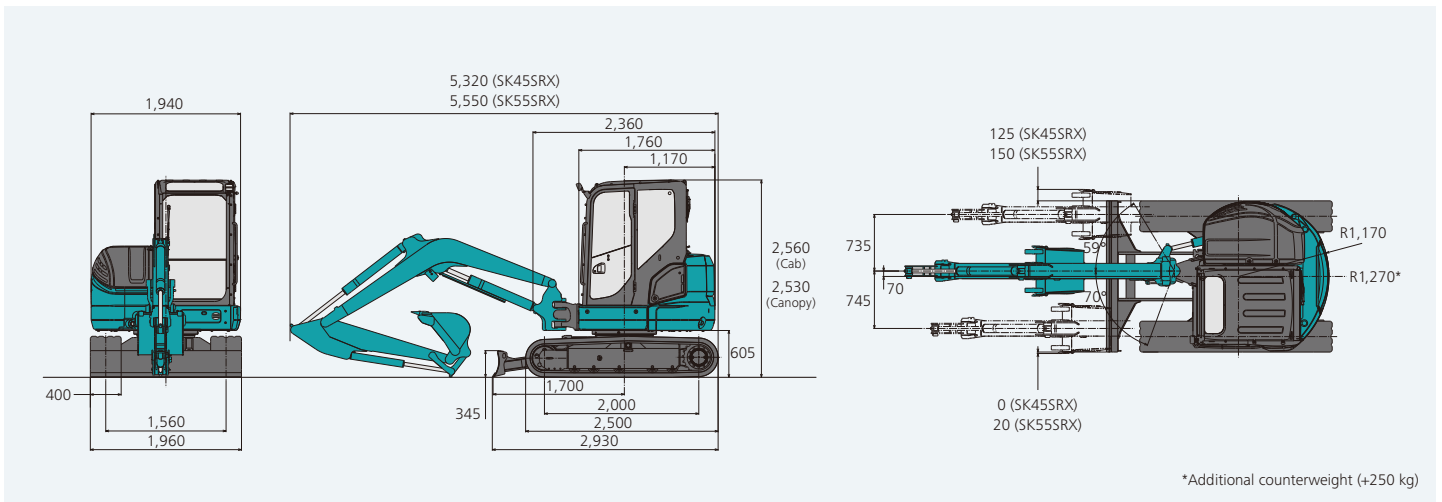













## Operating weight & ground pressure













In standard trim, with standard boom, standard arm, and 0.14 m<sup>3</sup> (100 kg)–0.16 m<sup>3</sup> (110 kg) ISO heaped bucket













Model	SK45SRX				SK55SRX			
	Cab		Canopy		Cab		Canopy	
Shaped	Steel shoe	Rubber shoe	Steel shoe	Rubber shoe	Steel shoe	Rubber shoe	Steel shoe	Rubber shoe
Shoe width mm	400							
Overall width of crawler mm	1,960							
Ground pressure kPa	29.0	27.1	28.2	26.3	31.8	29.6	30.9	28.7
Operating weight kg	4,980	4,810	4,830	4,660	5,450	5,240	5,300	5,090













\*Regarding bucket capacity, 0.14 m<sup>3</sup> in this catalogue is equivalent to 0.12 m<sup>3</sup> in ISO 07451 and 0.16 m<sup>3</sup> in this catalogue is equivalent to 0.13 m<sup>3</sup> ISO 07451.

# Lift capacities

SK45SRX Canopy		Arm: 1.55 m Standard counterweight Rubber shoe: 400 mm												
B	A	1.0 m		2.0 m		3.0 m		4.0 m		5.0 m		At Max. Reach		Radius
														
5.0 m	kg											*1,250	*1,250	2.68 m
4.0 m	kg							*970	830			*880	810	4.03 m
3.0 m	kg					*1,160	*1,160	990	830			750	630	4.70 m
2.0 m	kg					1,520	1,240	950	790	670	560	660	550	5.03 m
1.0 m	kg					1,410	1,140	910	760	650	550	640	530	5.09 m
G.L.	kg					1,360	1,090	880	730			660	550	4.92 m
-1.0 m	kg	*1,860	*1,860	*2,540	2,140	1,360	1,090	880	730			760	630	4.46 m
-2.0 m	kg			2,940	2,200	1,390	1,130					1,070	880	3.58 m

SK45SRX Canopy		Arm: 1.55 m Additional counterweight (+ 250 kg) Rubber shoe: 400 mm												
B	A	1.0 m		2.0 m		3.0 m		4.0 m		5.0 m		At Max. Reach		Radius
														
5.0 m	kg											*1,250	*1,250	2.68 m
4.0 m	kg							*970	950			*880	*880	4.03 m
3.0 m	kg					*1,160	*1,160	1,130	950			*790	730	4.70 m
2.0 m	kg					*1,700	1,420	1,090	920	770	650	770	650	5.03 m
1.0 m	kg					1,620	1,320	1,050	880	760	640	740	620	5.09 m
G.L.	kg					1,570	1,280	1,030	850			770	650	4.92 m
-1.0 m	kg	*1,860	*1,860	*2,540	2,480	1,570	1,270	1,020	850			880	740	4.46 m
-2.0 m	kg			*2,960	2,540	1,610	1,310					1,240	1,020	3.58 m

SK45SRX Cab		Arm: 1.55 m Standard counterweight Rubber shoe: 400 mm												
B	A	1.0 m		2.0 m		3.0 m		4.0 m		5.0 m		At Max. Reach		Radius
														
4.0 m	kg							*970	860			880	850	4.03 m
3.0 m	kg					*1,160	*1,160	1,030	860			790	660	4.70 m
2.0 m	kg					1,580	1,290	1,000	830	700	590	700	580	5.03 m
1.0 m	kg					1,480	1,200	960	800	690	580	670	560	5.09 m
G.L.	kg					1,440	1,160	930	770			700	580	4.92 m
-1.0 m	kg	*1,860	*1,860	*2,540	2,250	1,430	1,150	930	770			800	670	4.46 m
-2.0 m	kg			*2,980	2,310	1,470	1,190					*1,130	*930	3.58 m

SK45SRX Cab		Arm: 1.55 m Additional counterweight (+ 250 kg) Rubber shoe: 400 mm												
B	A	1.0 m		2.0 m		3.0 m		4.0 m		5.0 m		At Max. Reach		Radius
														
4.0 m	kg							*960	*960			*870	870	4.03 m
3.0 m	kg					*1,160	*1,160	*1,150	980			*780	750	4.70 m
2.0 m	kg					*1,700	1,470	1,140	950	800	670	770	670	5.03 m
1.0 m	kg					1,690	1,370	1,100	910	790	660	770	640	5.09 m
G.L.	kg					1,640	1,330	1,070	890			800	670	4.92 m
-1.0 m	kg	*1,850	*1,850	*2,530	*2,530	1,640	1,330	1,070	880			*920	770	4.46 m
-2.0 m	kg			*2,970	2,640	1,670	1,360					*1,280	*1,060	3.58 m

# SK45SRX SK55SRX

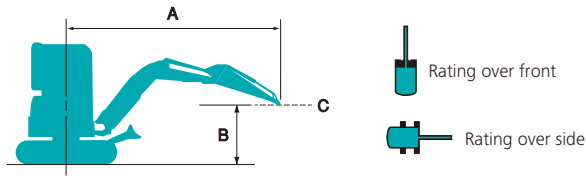

A: Reach from swing centreline to arm top  
 B: Arm top height above/below ground  
 C: Lift point  
 Bucket: Without  
 Dozer: Blade up  
 Relief valve setting: 23.0 MPa

SK55SRX Canopy		Arm: 1.69 m Standard counterweight Rubber shoe: 400 mm												
B \ A		1.0 m		2.0 m		3.0 m		4.0 m		5.0 m		At Max. Reach		Radius
5.0 m	kg											*1,050	*1,050	3.44 m
4.0 m	kg							*930	*930			960	810	4.52 m
3.0 m	kg							*1,000	970	810	680	780	650	5.10 m
2.0 m	kg					*1,610	1,430	1,120	930	790	670	700	590	5.40 m
1.0 m	kg					1,630	1,320	1,070	880	770	640	680	570	5.47 m
G.L.	kg					1,580	1,270	1,030	850	760	630	700	580	5.30 m
-1.0 m	kg	*1,980	*1,980	*2,490	2,470	1,580	1,270	1,020	840			780	650	4.89 m
-2.0 m	kg	*3,160	*3,160	*3,340	2,530	1,600	1,290	1,050	860			1,000	830	4.13 m
-3.0 m	kg			*1,570	*1,570							*1,120	*1,120	2.61 m

SK55SRX Canopy		Arm: 1.69 m Additional counterweight (+ 250 kg) Rubber shoe: 400 mm												
B \ A		1.0 m		2.0 m		3.0 m		4.0 m		5.0 m		At Max. Reach		Radius
5.0 m	kg											*1,050	*1,050	3.44 m
4.0 m	kg							*930	*930			*1,010	910	4.52 m
3.0 m	kg							*1,000	*1,000	910	770	880	750	5.10 m
2.0 m	kg					*1,610	1,610	*1,220	1,050	900	760	800	670	5.40 m
1.0 m	kg					1,850	1,500	1,210	1,010	880	740	770	650	5.47 m
G.L.	kg					1,790	1,450	1,170	970	860	720	800	670	5.30 m
-1.0 m	kg	*1,980	*1,980	*2,490	*2,490	1,790	1,450	1,170	970			890	750	4.89 m
-2.0 m	kg	*3,160	*3,160	*3,340	2,860	1,820	1,470	1,190	990			1,140	950	4.13 m
-3.0 m	kg			*1,570	*1,570							*1,120	*1,120	2.61 m

SK55SRX Cab		Arm: 1.69 m Standard counterweight Rubber shoe: 400 mm												
B \ A		1.0 m		2.0 m		3.0 m		4.0 m		5.0 m		At Max. Reach		Radius
5.0 m	kg											*1,050	*1,050	3.44 m
4.0 m	kg							*930	*930			1,000	840	4.52 m
3.0 m	kg							*1,000	*1,000	840	710	810	680	5.10 m
2.0 m	kg					*1,610	1,480	1,160	970	830	690	730	610	5.40 m
1.0 m	kg					1,700	1,370	1,110	920	810	670	710	590	5.47 m
G.L.	kg					1,650	1,320	1,080	890	790	660	730	610	5.30 m
-1.0 m	kg	*1,980	*1,980	*2,490	*2,490	1,650	1,320	1,070	880			820	680	4.89 m
-2.0 m	kg	*3,160	*3,160	*3,340	2,630	1,670	1,350	1,090	900			1,050	870	4.13 m
-3.0 m	kg			*1,570	*1,570							*1,120	*1,120	2.61 m

SK55SRX Cab		Arm: 1.69 m Additional counterweight (+ 250 kg) Rubber shoe: 400 mm												
B \ A		1.0 m		2.0 m		3.0 m		4.0 m		5.0 m		At Max. Reach		Radius
5.0 m	kg											*1,050	*1,050	3.44 m
4.0 m	kg							*930	*930			*1,010	940	4.52 m
3.0 m	kg							*1,000	*1,000	950	800	910	770	5.10 m
2.0 m	kg					*1,610	*1,610	*1,220	1,090	930	790	830	700	5.40 m
1.0 m	kg					1,920	1,550	1,250	1,040	910	770	800	680	5.47 m
G.L.	kg					1,860	1,500	1,220	1,010	900	750	830	700	5.30 m
-1.0 m	kg	*1,980	*1,980	*2,490	*2,490	1,860	1,500	1,210	1,000			920	770	4.89 m
-2.0 m	kg	*3,160	*3,160	*3,340	2,970	1,890	1,530	1,230	1,020			1,180	980	4.13 m
-3.0 m	kg			*1,570	*1,570							*1,120	*1,120	2.61 m

**Notes:**

- Do not attempt to lift or hold any load that is greater than these lift capacities at their specified lift point radius and heights. Weight of all accessories must be deducted from the above lift capacities.
- Lift capacities are based on machine standing on level, firm, and uniform ground. User must make allowance for job conditions such as soft or uneven ground, out of level conditions, side loads, sudden stopping of loads, hazardous conditions, experience of personnel, etc.
- Arm top defined as lift point.
- The above lift capacities are in compliance with ISO 10567. They do not exceed 87% of hydraulic lift capacity or 75% of tipping load. Lift capacities marked with an asterisk(\*) are limited by hydraulic capacity rather than tipping load.
- Operator should be fully acquainted with the Operator's and Maintenance Instructions before operating this machine. Rules for safe operation of equipment should be adhered to at all times.
- Lift capacities apply to only machine as originally manufactured and normally equipped by KOBELCO CONSTRUCTION MACHINERY CO., LTD.

# SK45SRX SK55SRX

---

Note: This catalogue may contain attachments and optional equipment that are not available in your area. And it may contain photographs of machines with specifications that differ from those of machines sold in your areas. Please consult your nearest KOBELCO distributor for those items you require.  
Specialist equipment is needed to use this machine in demolition work. Before using it please contact your KOBELCO dealer.  
Due to our policy of continuous product improvements all designs and specifications are subject to change without advance notice.  
Copyright by **KOBELCO CONSTRUCTION MACHINERY CO., LTD.** No part of this catalogue may be reproduced in any manner without notice.

---

## **KOBELCO CONSTRUCTION MACHINERY CO., LTD.**

5-15, Kitashinagawa 5-chome, Shinagawa-ku, Tokyo 141-8626 JAPAN  
Tel: +81 (0) 3-5789-2146 Fax: +81 (0) 3-5789-2135  
<https://www.kobelcocm-global.com/>

Enquiries To: