

COMPACT TRACK LOADER



Specifications

Operating Weight:	12,255 lbs (5559 kg)
Tipping Load:	10,700 lbs (4853 kg)
Ground Pressure:	4.3 psi (29.7 psi)
Gross Engine Power:	120 hp (89.5 kW)

Features

- Final Tier 4 Cummins engine with 360 ft-lbs torque.
- Special guarding for working in rugged, difficult environments.
- Patented undercarriage includes 20-inch (508 mm) wide rubber track, multiple levels of suspension and 48 rubber roller wheels per track.
- Two-speed hydraulic drive system offers fast travel speed and high torque work speed.
- Standard two-speed auxiliary hydraulic system and high-capacity cooling system are ideal for demanding applications.

WORKS FOR YOU.™

SPECIFICATIONS

R350T FORESTRY

OPERATING SPECIFICATIONS

Loader arms	Radial
Operating weight	12,255 lbs 5559 kg
Shipping weight	11,381 lbs 5162 kg
Ground pressure @ operating weight	4.3 psi 29.7 kPa
Rated operating capacity, 35% of tipping load	3,745 lbs 1699 kg
Operating capacity, 50% of tipping load	5,350 lbs 2427 kg
Tipping load	10,700 lbs 4853 kg
Travel speed, maximum - 1 st speed	6 mph 9.7 kph
Travel speed, maximum - 2 nd Speed	10 mph 16 kph

ENGINE

Type	Diesel, 4-cylinder, intercooled, turbocharged
Model	Cummins QSF3.8
Displacement	232 in ³ 3.8 L
Gross power rating @ 2800 rpm	120 hp 89.5 kW
Torque, peak	360 ft-lb 488 Nm
Cooling system	Hydraulically-driven fan and coolant/anti-freeze-filled radiator
Intake air cleaner	Three-stage
Emission controls	Meets all U.S. EPA Tier 4 final standards

UNDERCARRIAGE

Track type: General purpose track constructed of rubber compound with embedded co-polymer cords and all-purpose treads.	
Track width	20 in. 508 mm
Length of track on ground	71 in 1803 mm
Ground contact area	2,840 in ² 1.83 m ²
Drive system	Two hydrostatic direct drive sprockets controlled by a single joystick
Track drive sprocket	Elevated with low friction, replaceable sprocket rollers
Undercarriage suspension	Two independent torsion axles per undercarriage
Roller wheels	48 high-density polyurethane and rubber wheels per track. Wheels include sealed bearings
Roller wheel diameter:	
Front and rear wheels	15 in. 381 mm
Middle wheels	10 in. 254 mm

AUX. HYDRAULIC SYSTEM

Pump capacity: Low - variable from 0-20 gpm 75.7 lpm. High - 45 gpm 170 lpm	
System pressure, Low - 3,300 psi 22 750 kPa High - 4,060 psi 27 993 kPa	
Controls	Intermittent via joystick button or continuous via console switch, mode selectable via display
Couplers	Push-to-connect quick couplers mounted on loader arms Pressure relief valve mounted to coupler block
Cooling system	High efficiency side-by-side radiator and oil cooler

ELECTRICAL SYSTEM

Nominal charge	12 V
Battery	950 CCA
Charging system	120 amp alternator
Outlets	1-12 V port inside operator station
Wiring	Pre-wired for all factory-available accessories
Standard features	Attachment control kit, block heater, rear-view camera

OPERATOR STATION

Seat: Adjustable contour vinyl with built-in operator presence switch, lap bar and 2 in 51 mm wide seat belt	
Loader control: Right-hand pilot electronic joystick controls loader lift, lower and tilt, plus intermittent control of auxiliary hydraulic	
Drive control: Left-hand pilot electronic joystick controls machine speed and direction	
Engine speed	Hand-operated throttle
Indicators & gauges	Engine RPM, fuel level, coolant temperature, air inlet temperature, engine oil pressure, voltage, hydraulic oil temperature, travel speed, DEF level, engine hourmeter, trip meter
ROPS	Meets SAE J1040 APR88, ISO 3471:2008, ISO 8082-1:2009
FOPS	Meets ISO 3449:2005 level 2, ISO 8083:2006, BC WCB G608
OPS	Meets SAE J1084:2002, ISO 8084:2003, BC WCB G603:1990, BC WCB G604:1990
Illumination	2 - Adjustable forward-facing halogen lights 2 - Adjustable rear-facing halogen lights 1 - Interior light
Horn, backup alarm and 12 V power port standard	



R350T FORESTRY

DIMENSIONS: GENERAL PURPOSE BUCKET

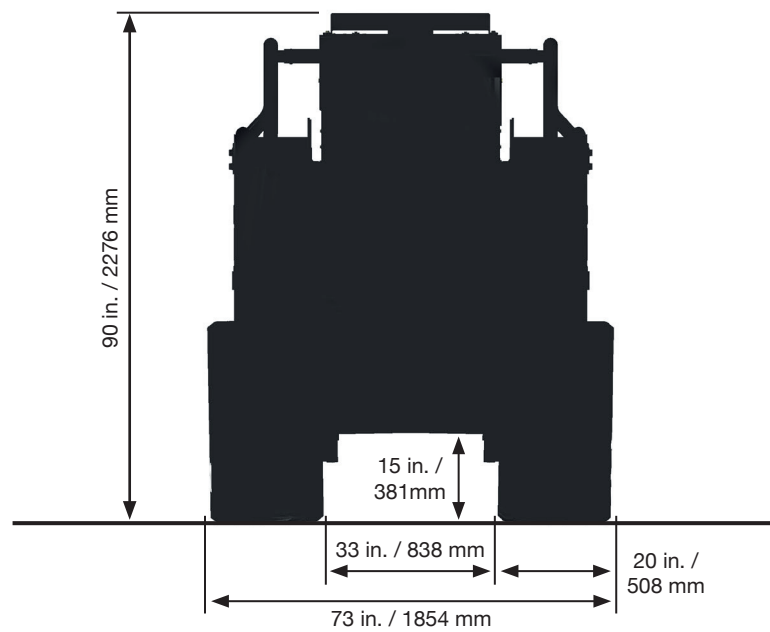
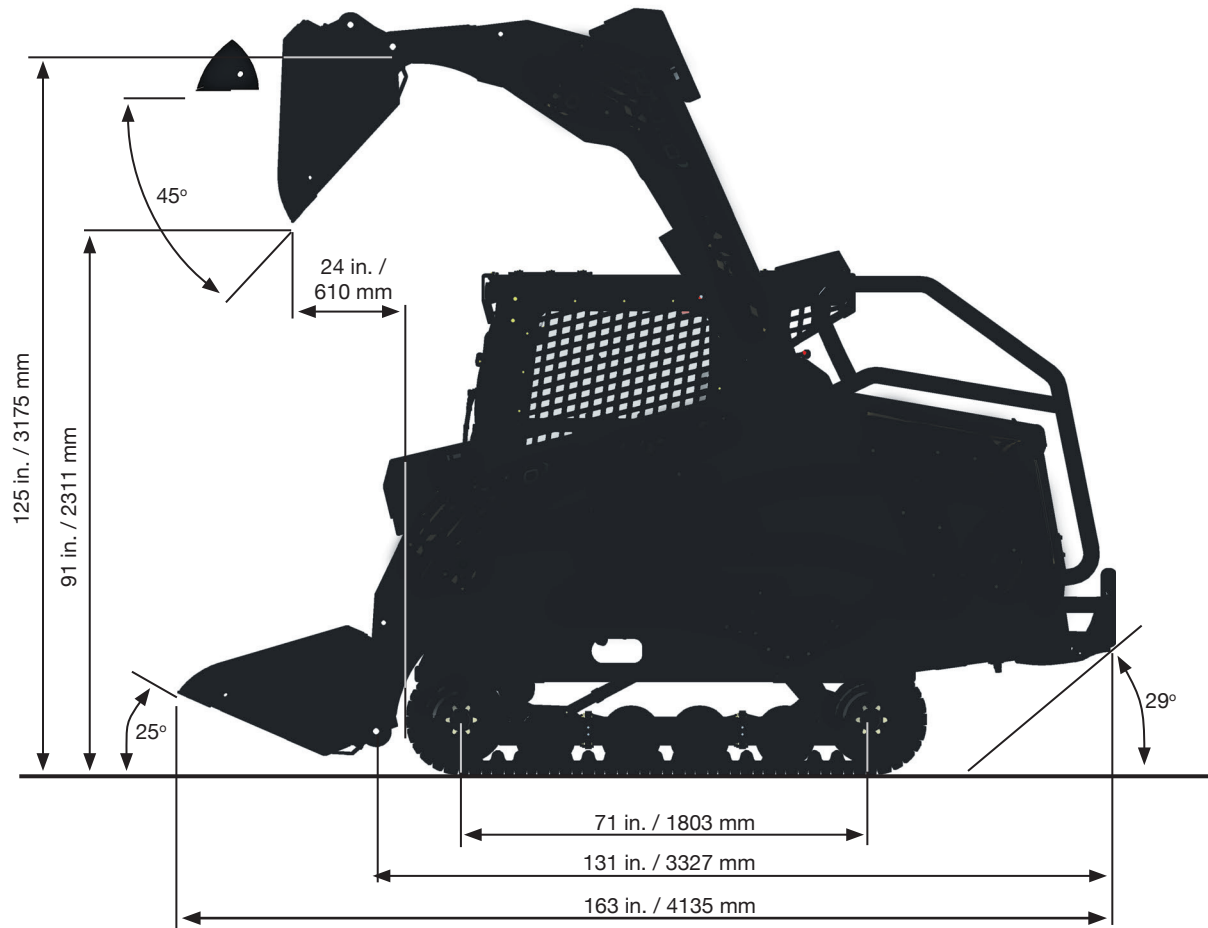



SPECIFICATIONS

R350T FORESTRY

SERVICE REFILL CAPACITIES

Fuel tank	30 gal 114 L
Hydraulic tank	22 gal 83 L
Engine coolant/antifreeze	5.5 gal 20.8 L
Engine oil, including filter	12 quarts 11.4 L

OPTIONAL ATTACHMENTS

Dirt bucket, 72 inch 1829 mm wide, or
Tooth bar, 74 inch 1880 mm wide
Loftness mulching head, 61 inch 1549 mm wide
Loftness mulching head w/Quadco teeth, 61 inches 1549 mm wide

www.terex.com

Effective Date: January 2016. Product specifications and prices are subject to change without notice or obligation. The photographs and/or drawings in this document are for illustrative purposes only. Refer to the appropriate Operator's Manual for instructions on the proper use of this equipment. Failure to follow the appropriate Operator's Manual when using our equipment or to otherwise act irresponsibly may result in serious injury or death. The only warranty applicable to our equipment is the standard written warranty applicable to the particular product and sale and Terex makes no other warranty, express or implied. Products and services listed may be trademarks, service marks, or trade names of Terex Corporation and/or its subsidiaries in the USA and other countries. All rights are reserved. Terex is a registered trademark of Terex Corporation in the USA and many other countries.

© 2016 Terex Corporation.
Terex Construction 8800 Rostin Road, Southaven, MS 38671 USA
Tel +1 (888) 90-TEREX www.terex.com



WORKS FOR YOU.™

