

ACR 60

RAMMER

HEIGHT, HANDLE MAKE A DIFFERENCE

The ACR 60 is the lightest of the Ammann Rammers, with a weight of 62 kg. It is used when a little less weight is sufficient – especially in particularly tight spaces. The handle offers high production while limiting the vibration levels that reach the operator and, of course, enables manoeuvrability. The highly reliable Honda GX 100 4-stroke petrol engine delivers sufficient power for all applications to the rammer. Alternatively the machine is available with a low emission engine, Honda GXR 120.

EXCELLENT DRIVE

- Low centre of gravity improves balance, prevents tipping and makes machine guidance easy.
- Best-in-class forward-moving abilities thanks to superior machine balance.

USER FRIENDLY HANDLE

- Limits vibration to operator and reduces fatigue.
- Adjustable in height to make the work more comfortable for each individual operator.
- Enables machine to be held and operated from all sides to reach tight areas and work in narrow spaces.
- Open handle bar allows to view the foot at any time.

CONVENIENT AIR FILTRATION

- The high-performance air filter is fixed horizontal in a secure position and can be maintained without any tools.
- Optional available cyclone pre filter with low pressure indicator extends lifetime of your filter up to 5 times.

THE SHOE FITS

- Standard 280 mm foot.
- Seven shoe sizes available including an asymmetric option for compaction along walls and curbs.
- Wear-resistant ramming shoe with integrated steel plate.
- Switching shoes requires removal of only four screws.
- Light guide tube assembly

APPLICATIONS

- Trench compaction
- Back filling
- Pipe work
- Foundation work
- Patch work on roads
- Confined areas

AMMANN

TECHNICAL SPECIFICATIONS
ACR 60 RAMMER

WEIGHT & DIMENSIONS

MACHINE WEIGHT	62 kg (137 lb)
A FOOT LENGTH	340 mm (13 in)
B FOOT WIDTH	280 mm (11 in)
C HANDLE LENGTH	710 mm (28 in)
D MACHINE HEIGHT	1020 mm (40 in)
E HANDLE WIDTH	355 mm (14 in)

ENGINE

ENGINE	Honda GX 100 / Honda GXR 120
FUEL	Petrol
ENGINE OUTPUT	2.2 kW (3 HP) / 2.7 kW (3.7 HP)
AT RPM	4300

COMPACTION FORCES

PERCUSSION RATE	680 bpm
STROKE HEIGHT	65 mm (2.6 in)
CENTRIFUGAL FORCE	11.5 kN (2.6 lbf)
SURFACE CAPACITY	225 m ² /h (2422 ft ² /h)
MAX. COMPACTION PERFORMANCE (DEPENDING ON GROUND CONDITIONS)	45 cm (18 in)

MISCELLANEOUS

FUEL TANK CAPACITY	3.5 l (0.8 gal)
TRAVEL SPEED	13.5 m / min (0.5 mph)
OPTIONAL FOOT SIZES WIDTH	165–200–230–330–400 mm (6.5–7.87–9.1–13–16 in)

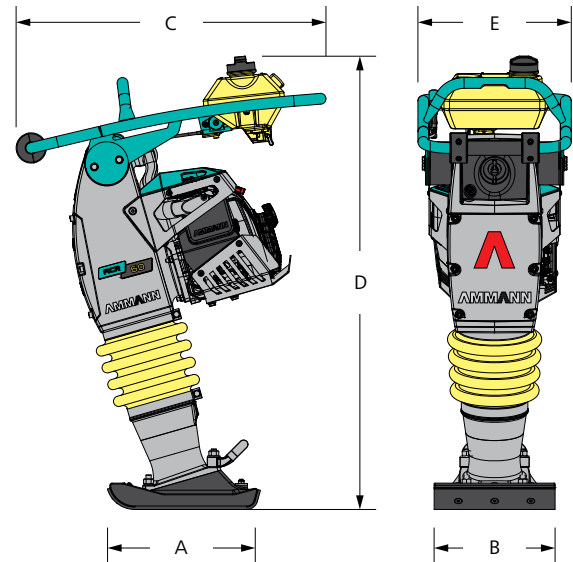

STANDARD EQUIPMENT

- Vibration isolated guide handle
- Carburetor with integrated accelerator pump for trouble free quick engine start
- Oil alert system with LED indicator
- Large fuel tanks
- High quality, wear resistant 280 mm base plate
- Honda engine with reliable starter
- Convenient rolls for easy loading and unloading
- Petrol engine requires no fuel mixing at the job site

OPTIONAL EQUIPMENT

- Adaptor plate for 10 cm height reduction
- Cyclone pre cleaner for air filter extends lifetime of the filter by 5 times
- Seven different sized foot plates from 165 mm to 400 mm
- 340 mm asymmetric foot plate for compaction up to walls and curbs
- Transport wheels
- Operation hour meter