

# PANORAMIC P40.17

- ▶ **Kubota Tier III Engine, 100Horsepower**
- ▶ **40km/hr ensure unrivalled driving ability** in most challenging ground
- ▶ **Frame Levelling system** allows chassis to be levelled for true vertical lift
- ▶ **Tac-Lock system** allows attachments to be interchanged from controls in the cab



SINCE 1964

First in **performance and reliability**, maximum stability within minimum space



# PANORAMIC P40.17

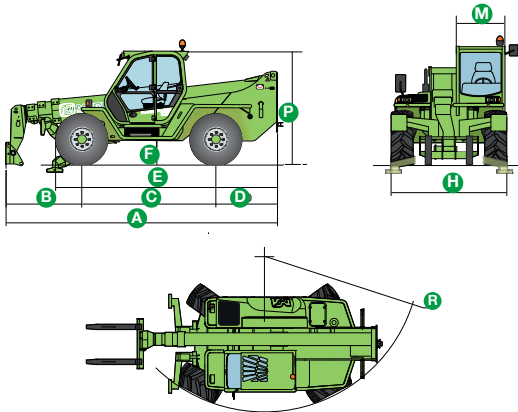

## DIMENSIONS

A (mm)	5,795
B (mm)	1,505
C (mm)	2,875
D (mm)	1315
E (mm)	4,790
F (mm)	480
H (mm)	2,400
M (mm)	995
P (mm)	2,510
R (mm)	4,050

## PERFORMANCE

Unladen Weight (kg)	10,580
Maximum Load Capacity (kg)	4000
Maximum Lift Height (m)	16.7
Capacity at Maximum Height (kg)	2,000
Maximum Reach (m)	12.5
Capacity at Maximum Reach (kg)	400
Boom Side-Shift (mm)	±435
Frame Levelling (%)	±10

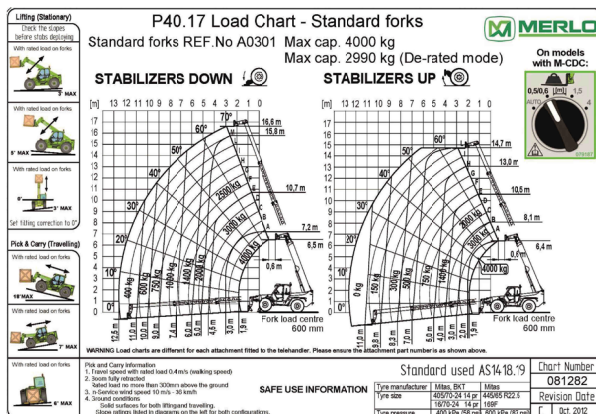

## STANDARD SPECIFICATIONS

### Engine

Turbo Engine	Kubota V3800 Euro III
Range/Cylinders	3800/4
Engine Power (kW/HP)	74/100
Maximum Speed (km/h)	40
Fuel Tank Capacity (l)	140

### Transmission

Hydrostatic Merlo Transmission	Std
Speeds	2
Dual Reverse Shuttle System	Std
Pedal Inching-Control	Std
Permanent Four-Wheel Drive	Std

### Brakes

Automatic Parking Brake	Std
External Dry Disc Service Brakes	Std

### Tyres

Standard Tyres	405/70-24
----------------	-----------

### Cab

Air Conditioned Cabin	Std
Air Suspension Seat	Std
FOPS (ISO 3449) and ROPS (ISO 3471) Cab	Std

### Steering

All Wheel Steering	Std
--------------------	-----

### Instruments

Electromechanical Joystick Control	Std
Merlo Dynamic Load Control (M-CDC)	Std
Reversing Camera	Std

### Hydraulic System-Implement

Load-Sensing Hydraulic System (bar-l/min)	210-115
Hydraulic Oil Tank Capacity (l)	105
Auxiliary Hydraulic Service on Boom	Std

### Accessories and Attachments

Tac-Lock Attachment Locking	Std
Standard Forks	Std
Fork Extensions	Optional
Digging Bucket	Optional
Re-Handling Bucket	Optional
4 x 1 Bucket	Optional
Crane Hook	Optional
Reduced Height Crane Jib	Optional
Drum Clamp	Optional
Fork Rotator	Optional
Man Platform	Optional
Carriage with floating forks	Optional

## EXTRA SPECIFICATIONS

Stabilisers	Std
Boom Side Shift	Std
Frame Levelling	Std



120-124 Toongabbie Road Girraween 2145 NSW Australia  
For further information please call **1300 657 325** or visit [merloaustralia.com.au](http://merloaustralia.com.au)

Merlo reserves the right to modify and update the contents of this document at any time. Information and technical data are as available at time of printing.

For current information on Merlo products please contact your Merlo dealer.

ABN 87116110751 **MER-P40.17-2018**